

YAMAHA AX-55

*Natural Sound Stereo Integrated Amplifier
Low 0.03% Distortion, 25 Watts Output Power per Channel
Auto Function Compatibility for One-Touch Source Selection
Compact Design with Sensor-Touch Controls
Volume Control with 41-Segment Volume Indication*

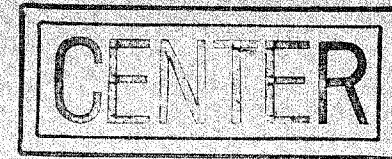

OWNER'S MANUAL



Thank you for purchasing the YAMAHA AX-55 stereo amplifier.

CONTENTS

CAUTION: READ THIS BEFORE OPERATING YOUR AX-55	1/2
CONNECTION DIAGRAM	3
CONNECTIONS	4
FRONT AND REAR PANELS PARTS AND FUNCTIONS	5/6/7
LISTENING	7
TROUBLESHOOTING	8
SPECIFICATIONS	9

IMPORTANT

Please record the serial number of your unit in the space below.

Model: AX-55

Serial No.:

The serial number is located on the rear of the cabinet.

Retain this Owner's Manual in a safe place for future reference.

WARNING

To prevent fire or shock hazard, do not expose this appliance to rain or moisture.

CAUTION (PREPARED IN ACCORDANCE WITH UL STANDARD 1270)

1 Read Instructions — All the safety and operating instructions should be read before the appliance is operated.

2 Retain Instructions — The safety and operating instructions should be retained for future reference.

3 Heed Warnings — All warnings on the appliance and in the operating instructions should be adhered to.

4 Follow Instructions — All operating and other instructions should be followed.

5 Water and Moisture — The appliance should not be used near water — for example, near a bathtub, washbowl, kitchen sink, laundry tub, in a wet basement, or near swimming pool, etc.

6 Carts and Stands — The appliance should be used only with a cart or stand that is recommended by the manufacturer.

7 Wall or Ceiling Mounting — The appliance should be mounted to a wall or ceiling only as recommended by the manufacturer.

8 Ventilation — The appliance should be situated so that its location or position does not interfere with its proper ventilation. For example, the appliance should not be situated on a bed, sofa, rug, or similar surface that may block the ventilation openings; or placed in a built-in installation, such as a bookcase or cabinet that may impede the flow of air through the ventilation openings.

9 Heat — The appliance should be situated away from heat sources such as radiators, stoves, or other appliances that produce heat.

10 Power Sources — The appliance should be connected to a power supply only of the type described in the operating instructions or as marked on the appliance.

11 Power-Cord Protection — Power-supply cords should be routed so that they are not likely to be walked on or pinched by items placed upon or against them, paying particular attention to cords at plugs, convenience receptacles, and the point where they exit from the appliance.

12 Cleaning — The appliance should be cleaned only as recommended by the manufacturer.

13 Nonuse Periods — The power cord of the appliance should be unplugged from the outlet when left unused for a long period of time.

14 Object and Liquid Entry — Care should be taken so that objects do not fall into and liquids not spilled into the inside of the appliance.

15 Damage Requiring Service — The appliance should be serviced by qualified service personnel when:

- A. The power-supply cord or the plug has been damaged; or
- B. Objects have fallen, or liquid has been spilled into the appliance; or
- C. The appliance has been exposed to rain; or
- D. The appliance does not appear to operate normally or exhibits a marked change in performance; or
- E. The appliance has been dropped, or the cabinet damaged.

16 Servicing — The user should not attempt to service the appliance beyond those means described in the operating instructions. All other servicing should be referred to qualified service personnel.

**CAUTION: READ THIS BEFORE
OPERATING YOUR AX-55**

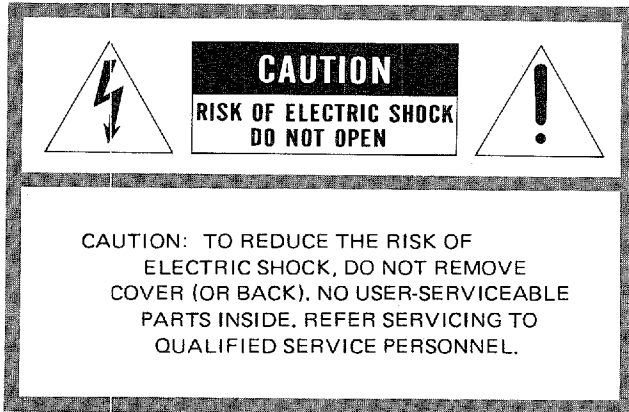

• Explanation of Graphical Symbols

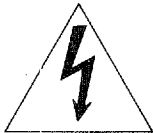

The lightning flash with arrowhead symbol, within an equilateral triangle, is intended to alert you to the presence of uninsulated "dangerous voltage" within the product's enclosure that may be of sufficient magnitude to constitute a risk of electric shock to persons.

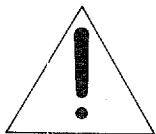

The exclamation point within an equilateral triangle is intended to alert you to the presence of important operating and maintenance (servicing) instructions in the literature accompanying the appliance.

1

The AX-55 is a sophisticated stereo integrated amplifier. To ensure proper operation for the best possible performance, please read this manual carefully.

2

Choose the installation location of your AX-55 carefully. Avoid placing it in direct sunlight or close to a source of heat. Also avoid locations subject to vibration and excessive dust, heat, cold or moisture. Keep it away from such sources of hum as transformers or motors.

3

Do not open the cabinet as this might result in damage to the set or electrical shock. If a foreign object should get into the set, contact your dealer.

4

Do not place records or other objects on top of the amplifier so that the ventilation holes are blocked. This will cause the internal temperature to rise and may result in a failure.

5

When removing the power plug from the wall outlet, always pull directly on the plug; never yank the cord.

6

To prevent lightning damage, pull out the power cord.

7

Do not use force when using the switches and knobs.

8

When moving the set be sure to first pull out the power plug and remove cords connecting to other equipment.

9

Always set the volume control to "0" while lowering the tonearm to play a record, then turn the volume up after the stylus is seated in the record groove.

10

Do not attempt to clean the AX-55 with chemical solvents as this might damage the finish. Use a clean, dry cloth.

11

Be sure to read the "troubleshooting" section for advice on common operating errors before concluding that your AX-55 is faulty.

12

Keep this manual in a safe place for future reference.

13

Do not connect audio equipment to the AC outlets on the rear panel if that equipment requires more power than the outlets are rated to provide.

AX-55

CONNECTION DIAGRAM

Before making any connections, turn off all equipment.

The control signal cord for the PX-55 also serves as the ground, so no ground is necessary.

Read the tuner owner's manual to connect the tuner antenna.

Make sure that the amplifier ventilation openings are not covered by any other component except tuner model TX-77, as this may generate hazardous temperature.

Connect the units with the supplied special power connector, as shown in the diagram.

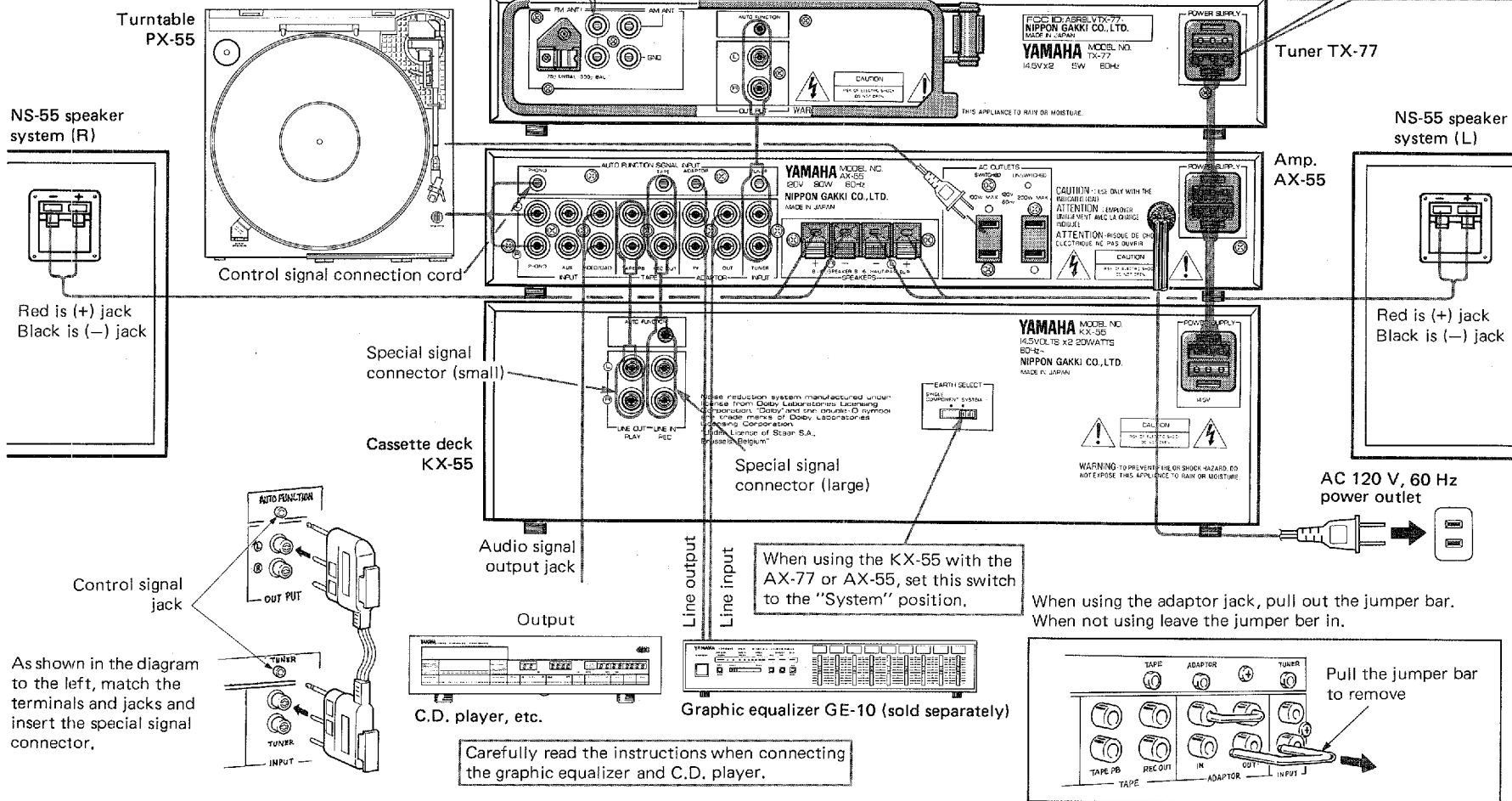

CONNECTIONS

■ CONNECTING THE SPEAKER SYSTEM

Connect the cords going to the left speakers to the L terminals and the right speaker cords to the R terminals, making sure that the "+" and "-" markings are observed. If the "+" and "-" wires are reversed at either speaker, the sound will be unnatural and will lack bass. Speaker cords should be cut as short as possible; do not coil up excess wire on the floor. Also, do not bundle with cords from other system components.

Push in on the lever at the terminal, insert the exposed wire of the speaker cord into the hole and then release the lever. The cord will be locked into position. If these connections are faulty, no sound will be heard from the speakers. **(Note)** Use a speaker with an impedance of 8 - 16 Ω.

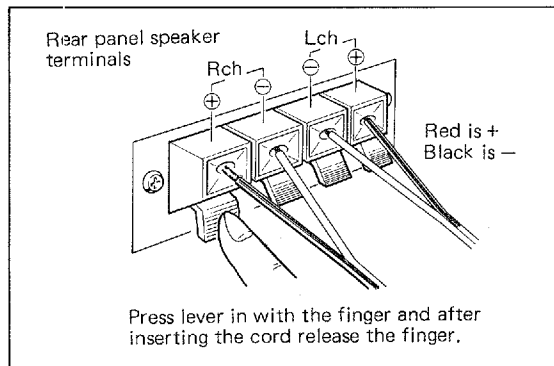

■ SAFETY FUNCTION

Should an abnormality arise when the power is switched on, such as a short in the speaker cord, the amp volume will automatically be cut to "0" and the input selector will not operate. When the abnormal condition is corrected the unit will operate normally when the power is switched on again.

■ CONNECTING A TAPE DECK

Check left and right cords, then connect the terminals.

AMP (Rec Out jack ↔ Line In jack) TAPE DECK
 (Tape Playback jack ↔ Line Out jack)

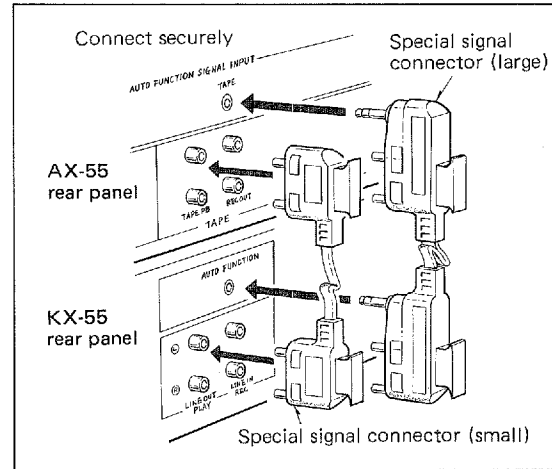

■ REAR PANEL POWER OUTLET

- Equipment consuming less than 100 watts of power can be connected to the switched outlet. By turning the power switch on the power can be switched on or off with the power switch of the main unit.
- Equipment consuming less than 200 watts of power can be connected to the unswitched outlet. This is not connected to the power switch of the main unit.

■ CONNECTING THE CONTROL SIGNAL

There is an auto function signal output for the turntable, the tuner, and the tape deck. Connect the input and output for each control signal and when the operations shown below are made the amp function will automatically switch over without any need for manual switching.

	Operation	Amp function
Turntable (PX-55)	The tone arm moves over the record.	PHONO
Tuner (TX-77)	• Turn power switch ON • Switch to FM or AM • Preset tuning • Manual tuning	TUNER
Tape deck (KX-55)	• Press playback button	TAPE

- * If the amp function is switched over while a record is being played, the tone arm will lift and will return to the arm rest. Also, if the function is switched while a tape is being played the tape deck will automatically stop.
 - * If the tuner is already tuned to the station you want to listen to, press the band selector once again and the amp function will switch to TUNER.
- Refer to the connection diagram when connecting the turntable and the tuner, paying attention to left and right connections. Also, read the instructions carefully when connecting a graphic equalizer, video, DAD player, etc.

AX-55

FRONT AND REAR PANELS PARTS AND FUNCTIONS

● FRONT PANEL

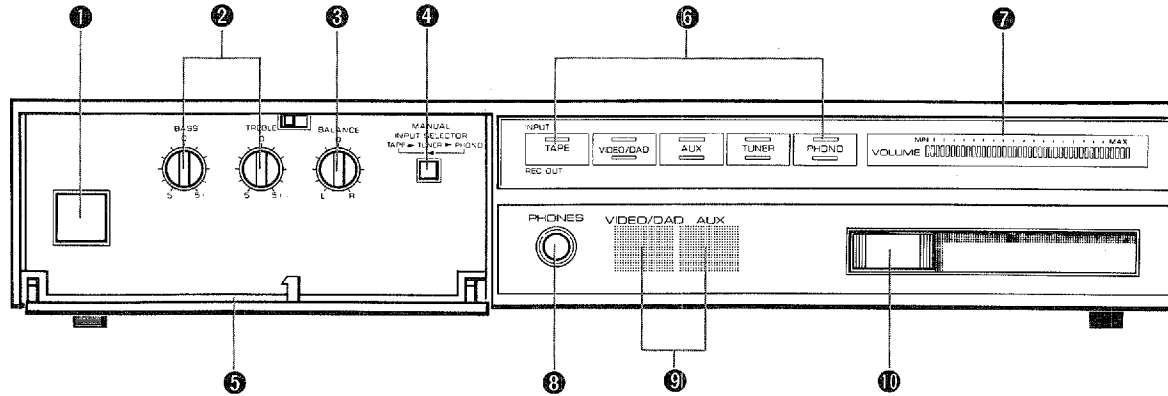

● REAR PANEL

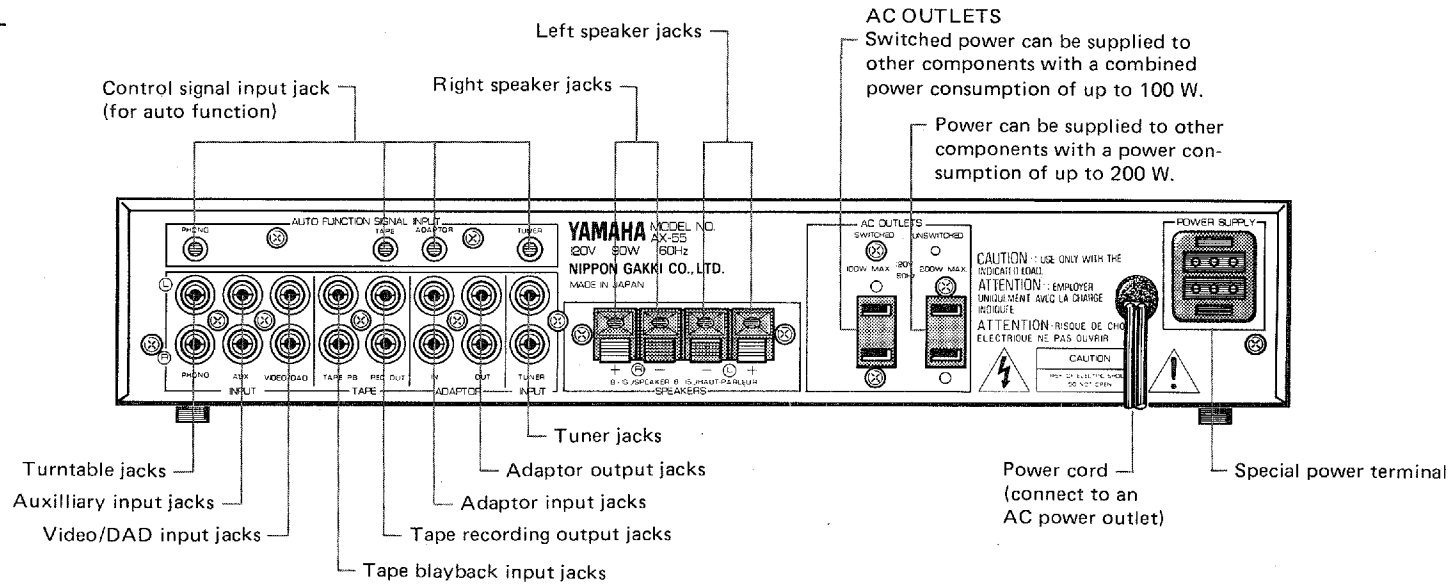

① POWER SWITCH

When the switch is pressed, the power will turn on and the lamp will light. When pressed again the power will turn off. When the power is switched on the function will be preset to TUNER.

② TONE CONTROLS

BASS At "0" the characteristics will be flat. When turned to the right the bass will be emphasized and when turned to the left the bass is deemphasized.

TREBLE At "0" the characteristics will be flat. When turned to the right the treble will be emphasized and when turned to the left the treble will be deemphasized.

③ BALANCE CONTROL

This control lets you adjust the relative volume of the left and right speakers, enabling you to compensate for unbalance caused by installation locations of the speakers and furniture arrangement.

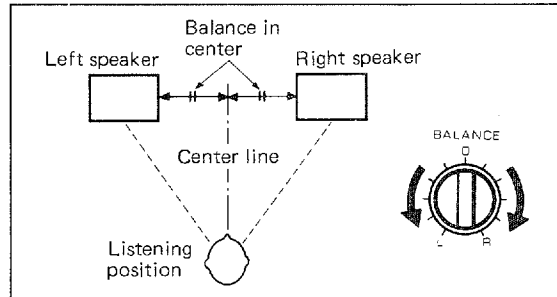

④ MANUAL INPUT SELECTOR

This unit has an auto function, so normally there is no need to operate this selector. However, the input source can be selected manually.

With each press of the button, you can switch to TAPE → TUNER → PHONO → TAPE and to INPUT REC OUT indicator ⑧. Tune in to the program you wish to listen to.

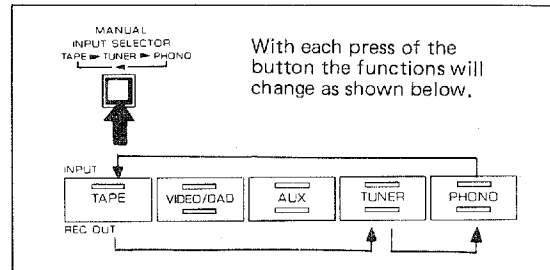

⑤ HINGED PANEL

When the hinged panel is closed the knobs not normally used will be out of sight, presenting a clean panel face. To open the panel press lightly on the Δ mark at the top of the panel.

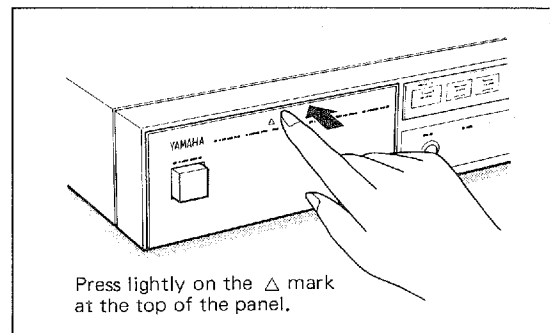

Press lightly on the Δ mark at the top of the panel.

⑥ INPUT/REC OUT INDICATOR

The upper indicator shows the input source while the lower shows the recording source.

This indicates the source selected with the manual input selector or through the operation of the tuner and the turntable.

(When power is turned on, the tuner will be selected.)

* Concerning recording, refer to the owner's manual of your deck.

⑦ VOLUME INDICATORS

Indicates the volume level as set by the volume control ⑩

⑧ HEADPHONE JACK

Insert the headphone plug. When inserted there will be no sound from the speakers.

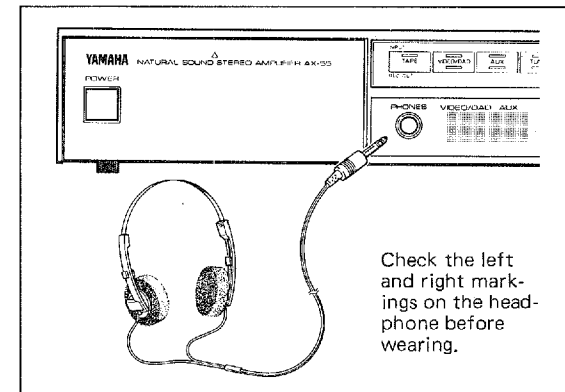

Check the left and right markings on the headphone before wearing.

9 AUXILIARY INPUT SELECTOR

A video deck or DAD player can be connected to the rear panel. This selector is used when listening to or recording the input sources. (The INPUT/REC OUT indicator ③ corresponding to the selector will light up.)

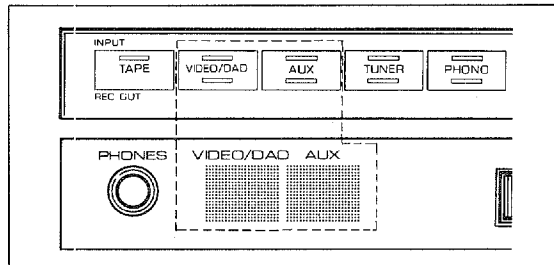

10 VOLUME CONTROL

Adjusts the volume. When the knob is slid to the right the volume will become louder and will be indicated by the volume indicators ⑦.

* The volume should always be set at low when turning the power switch on or off, or when changing the function. Also, when lowering the stylus onto the record or when raising the stylus the volume should be kept at low.

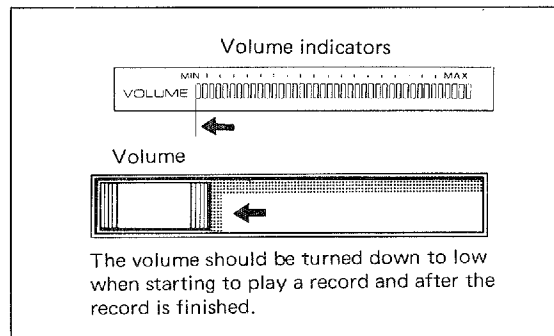

LISTENING

Check the connections once again before switching the power on.

- Are the plus and minus sides of the connection cord for the speaker system correct?
- Are all connection cords firmly connected? Also, before switching on, place the amp volume at the minimum position.

RECEIVING AM AND FM BROADCASTS

1. Follow the directions for "Tuning Procedures" in the tuner owner's manual.
2. Adjust the sound volume and tone with the amp.

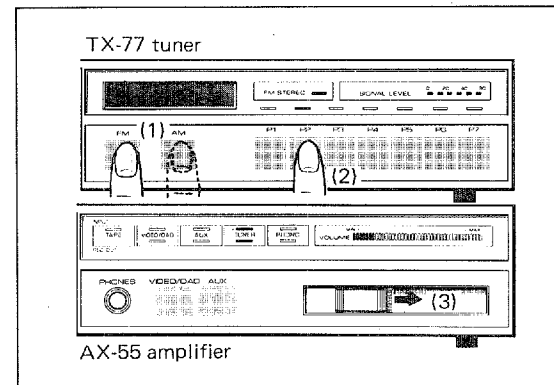

AX-55 amplifier

RECORD PLAYING

1. Before playing a record (when the stylus is lowering onto the record) and at the end of the record (when the stylus is rising) the volume should be set at the minimum volume.
2. Follow the turntable owner's manual to play records.
3. Adjust the volume and tone with the amp.

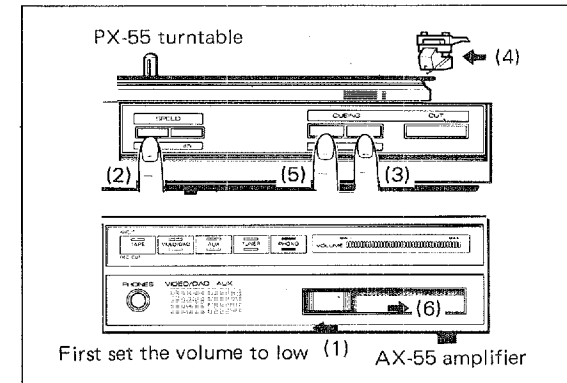

First set the volume to low (1) AX-55 amplifier

* To switch from record play to tape play, by operating the deck ▷ (play) switch record play will be automatically interrupted and the amp function will change to "TAPE", thus permitting tape playback with a single touch. (Refer to auto function on Page 4.)

TAPE DECK PLAYBACK

1. Following the instructions in the cassette deck owner's manual, place the tape in the playback condition.
2. Adjust the volume and tone with the amp.

- For recording, refer to the cassette deck owner's manual.

AX-55

TROUBLESHOOTING

Check the following items should an abnormality occur during use. Should the condition continue, pull the power plug out of the outlet and take the unit to the store where you made the purchase.

Condition	Cause	Remedy
There is no power even when the power switch is turned on.	The power plug is not firmly plugged into the wall outlet.	Plug the power plug firmly into the wall outlet.
There is absolutely no playback sound even when switched to function.	The volume is too low.	Raise the volume
	The pin plug of the input jack is not plugged in securely.	Plug the pin plug in securely.
	The amp is not connected securely to the speaker.	Check the connections.
There is no sound from both speakers or from one of the speakers.	The connection between the amp and the speaker is insufficient.	Check the connections.
	The balance is too much to the left or to the right.	Adjust with the balance knob.
The sound image is not stable and is unnatural with no bass sound.	The phase (+, -) of the amp and the speaker does not match.	Match the phase (+, -) to the amp and reconnect.
When playing a record, there is a humming sound.	The pin plug connection is not correct.	Plug the pin plug in securely.
	The control signal output jack is loose.	Connect the control signal output jack correctly.
The function and preset volume do not operate.	There is a short in the speaker cord.	Correct the short and switch power on again.
There is a howling sound when the volume is turned up when playing a record.	The turntable is too close to the speaker system or it is not on a level surface.	Change the position of the turntable and the speaker system. (Avoid the corners of the room.)

AX-55

SPECIFICATIONS

Continuous RMS Output Power (8 Ω)

20 Hz ~ 20 kHz, THD 0.03%	25 W + 25 W
1 kHz, THD 0.03%	28 W + 28 W

Power Bandwidth

(THD 0.06%, 12.5 W/8 Ω), . . . 10 Hz ~ 40 kHz

Damping Factor

(1 kHz, 8 Ω) 60

Input Sensitivity/Impedance

PHONO MM/MC	1.8 mV/47 k Ω
AUX, TAPE, TUNER	150 mV/50 k Ω

Frequency Response

AUX, TAPE, TUNER	+0
	-3 dB (5 Hz ~ 100 kHz)

RIAA Equalization Deviation

PHONO \pm 0.3 dB (30 Hz ~ 15 kHz)

Total Harmonic Distortion (20 Hz ~ 20 kHz)

PHONO \rightarrow REC OUT	0.02%
AUX, TAPE, TUNER \rightarrow SP OUT (12.5 W/8 Ω)	0.025%

Intermodulation Distortion (Rated output/8 Ω)

AUX, TAPE, TUNER 0.02%

Signal-to-Noise Ratio (IHF-A-Network)

PHONO (5mV, Input shorted)	88 dB
AUX, TAPE, TUNER (Input shorted)	100 dB

Residual Noise

(IHF-A-Network) 195 μ V

Channel Separation (PHONO/AUX, TAPE)

40 Hz	80 dB
1 kHz	80 dB
10 kHz	60 dB

Tone Control Characteristics

BASS (turnover frequency 350 Hz)	\pm 10 dB (20 Hz)
TREBLE (turnover fre- quency 3.5 kHz)	\pm 10 dB (20 KHz)

Power Supply AC 120 V, 60 Hz

Power Consumption 110 W

AC Outlet

Switched	100 W Max.
Unswitched	200 W Max.

Dimensions (W x H x D) 340 x 67 x 264 mm (13-3/8 x 2-5/8 x 10-3/8")

Weight 4.6 kg (10.12 lbs)

Accessories Sub-power plug 3 P connection plug

* Specifications subject to change without notice.

SINCE 1887



YAMAHA

NIPPON GAKKI CO., LTD. HAMAMATSU, JAPAN

8212 Printed in Japan \oplus